e2HC - connection diagram



Revision History

Date	Version	Description
08/03/2024	1.0	First version of document



Acronyms

e2HC: Elements 2 channels high current amplifier.

ch#: input pins.

GND: ground. The potential of the Faraday cage.

REF: reference.

DUT: device under test. Usually a flow cell with a membrane or a nanopore, but can also be a model cell with resistors and/or capacitors.

BLM: bi-layer membrane. A membrane composed of 2 layers of phospholipids as happens in cell membranes.

EMI: electro-magnetic interference. Environmental noise affecting the measurements.



Front and rear view

e2HC front-side connections



e2HC back-side connections

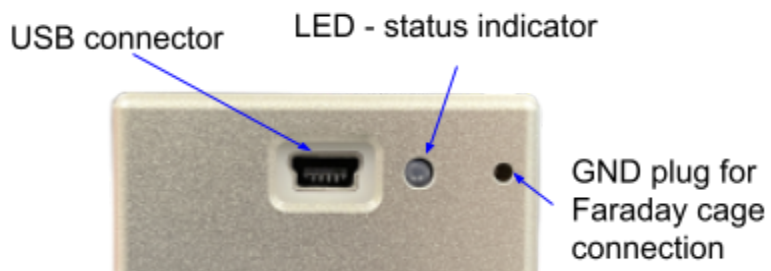



e2HC setup

The e2HC is directly plugged to the computer via a USB cable and it forms a complete and stand-alone system. The USB cable is used for both data communication and as the power supply.

The device should be placed in a Faraday cage that should be connected to the GND plug using the GND cable to shield it from EMI.

IMPORTANT NOTE: do not connect the Faraday cage to any part of the device other than the GND plug in order to avoid short circuits. A good strategy is to add a layer of insulating material (e.g. tape) to the internal surface of the Faraday cage.

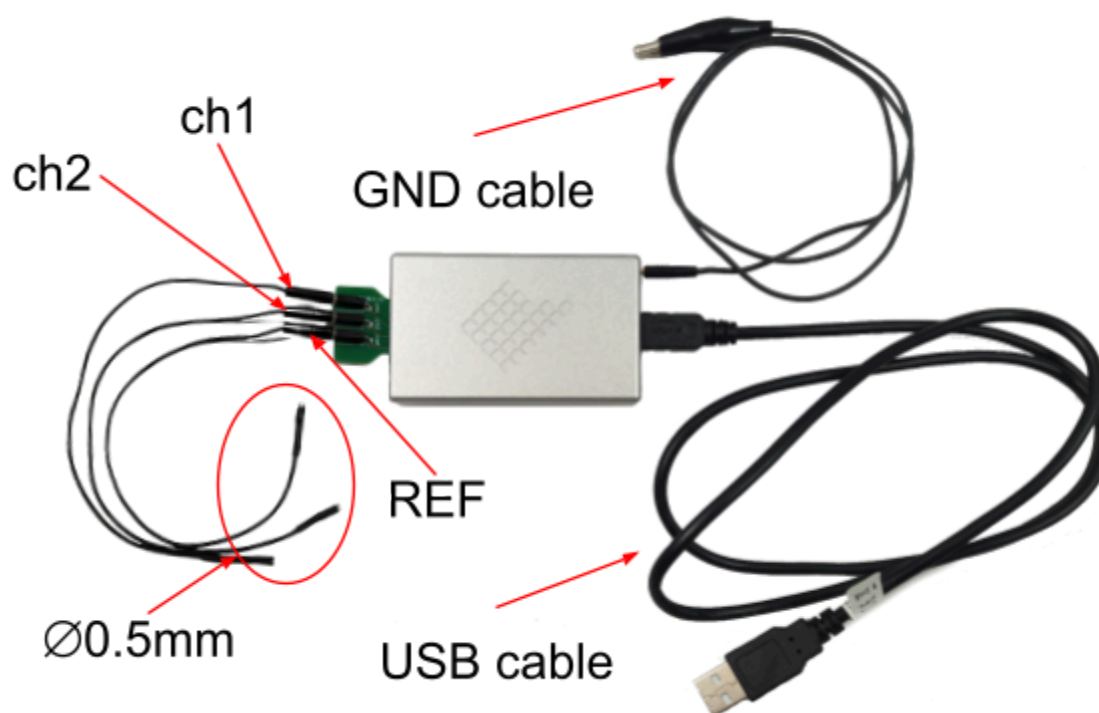



The figure below shows how to connect the e4 to the DUT, to the Faraday cage and to the computer.

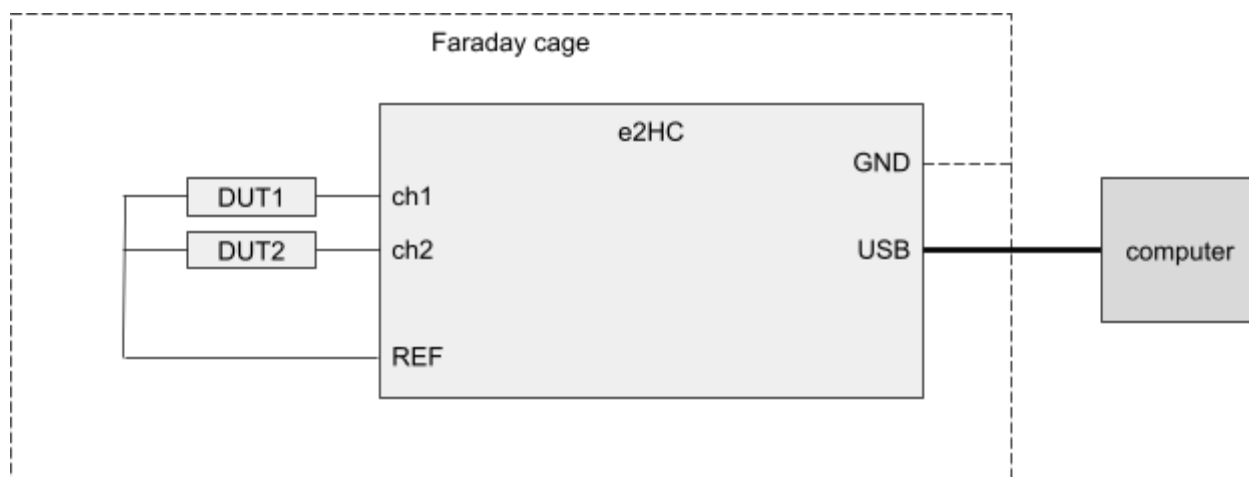

The scheme below shows how the control voltages are applied and the polarity of the acquired currents.

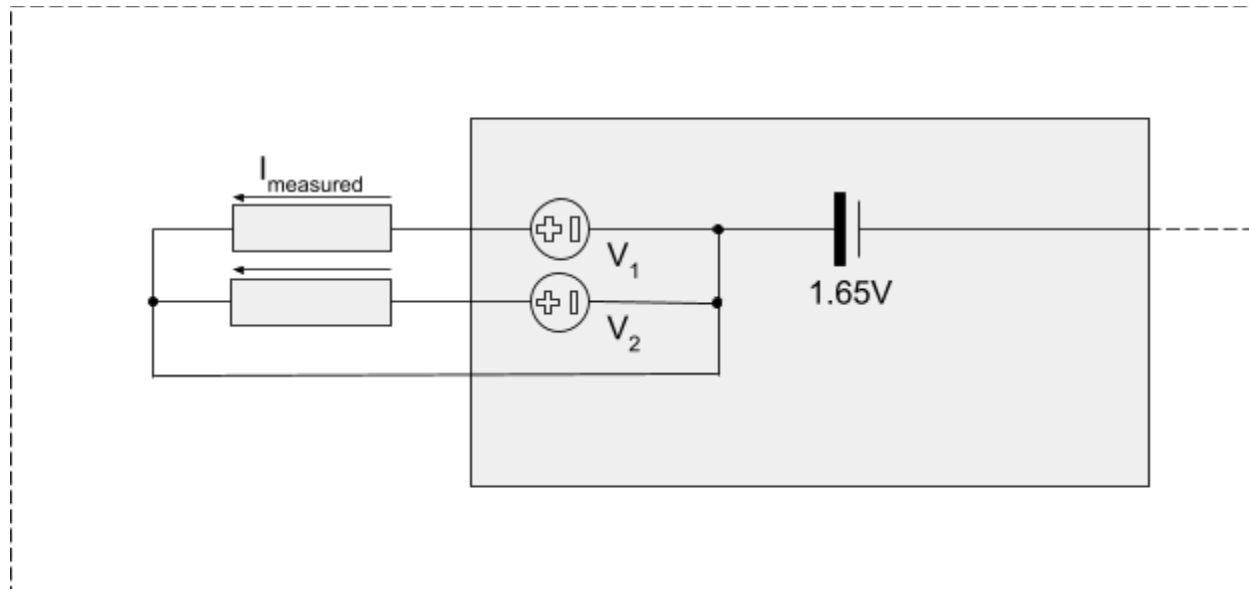

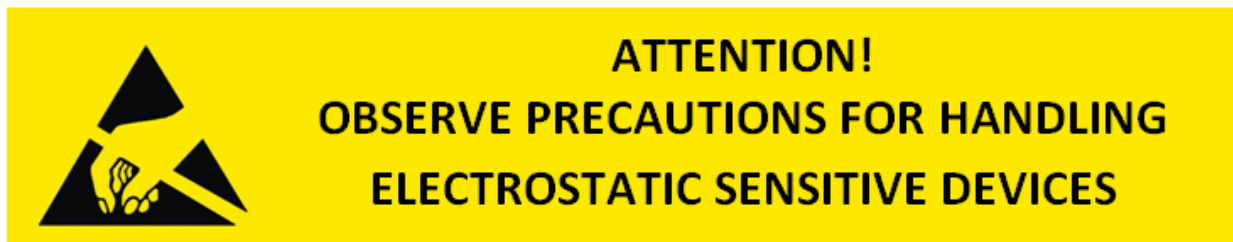

Connections best practices

The way the experiment is setup greatly affects the final quality of the measurements, especially in terms of signal to noise ratio.

In the following some best practices are described to help you get the most out of your device.

- **Shielding with a Faraday cage.** It is strongly recommended to enclose the device and the DUT in a Faraday cage that encloses the whole experimental setup, such as the ELEMENTS Faraday box ([p/n 000760](#)). The Faraday cage must be connected to the GND plug, using the provided GND cable.

Notice, when using a Faraday cage that the GND connector pin must fit completely within the amplifier's GND plug, otherwise the connection won't be good enough to provide proper grounding:

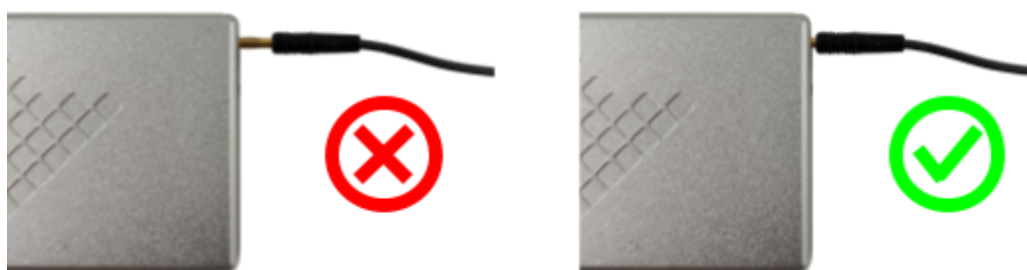

- **Avoid coupling with the Faraday cage.** If you are using a Faraday cage try to keep the device, the DUT and the cables between them as far as possible from the Faraday cage to reduce as much as possible the creation of stray capacitances.
- **Reduce the length of cables connecting the DUT.** The longer the cables, the more likely they will collect EMI or create stray capacitances with nearby conductive surfaces (such as the Faraday cage).
- **Avoid other instruments within the Faraday cage.** If you are using a Faraday cage, the e2HC is not shielded against the EMI from other instruments within the same



Faraday cage. So, if possible, remove them or keep them off to reduce the noise as much as possible.

- **Select instruments within the Faraday cage.** If you need to use other instruments within the same Faraday cage the best way to select your setup is to remove all of the instruments, close the Faraday cage and check the noise in this optimal condition. Then, add one instrument at a time and turn it on, to check how much it affects the measurement. These checks should be performed with the e4 configured as it will during the actual experiment (especially same current range and sampling rate).
- **Proper grounding.** If you are using a desktop computer be sure to power it up with a grounded power outlet or power strip. If you are using additional instruments within the Faraday cage be sure to power them up from a common power outlet or power strip.