

EDR3 - Voltage protocols

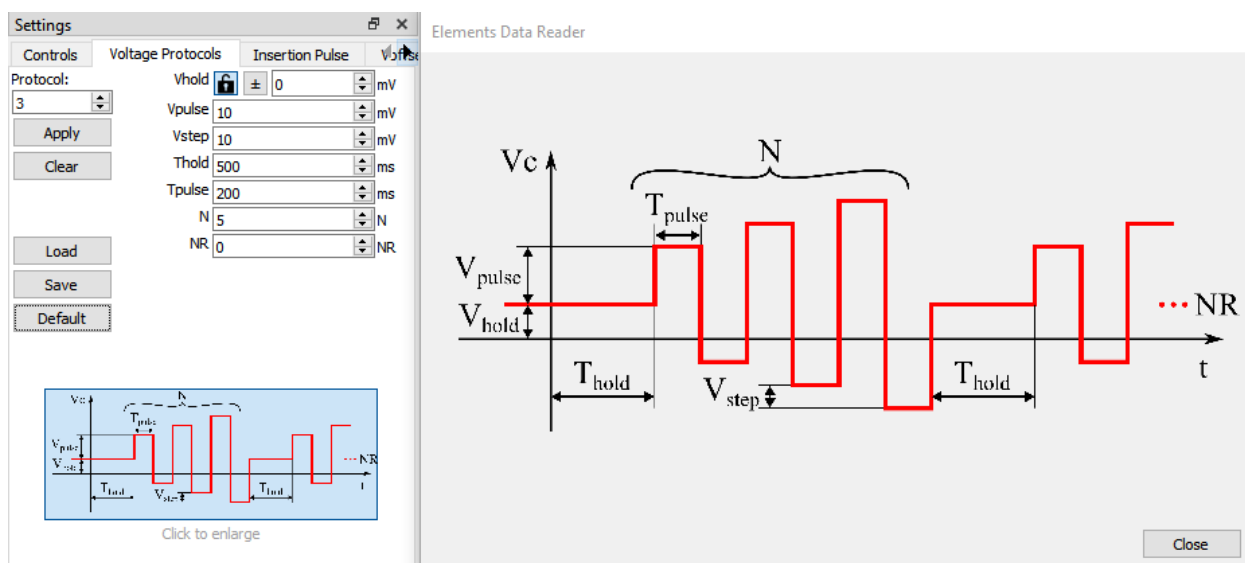

Revision History

Date	Version	Description
05/03/2020	1.1	Revised
16/01/2020	1.0	First version of document



The Voltage Protocols tab contains a complete set of parametric voltage stimulus protocols.

For each automatic voltage protocol the different parameters represented in figure can be set (see device specific guide for the complete list of voltage protocols available for every device, e.g. [e1b voltage protocols](#))

When the mouse hovers over the small voltage protocol image on the bottom of the protocol parameters a bigger image appears on the right. This image can be kept open by clicking on the small image and can be moved in a different position. This way, it will be easier to set all the parameters while keeping the bigger image opened for reference

Settings

Controls Voltage Protocols

Protocol: H

Apply Clear

Vhold \pm 0 mV

Vfp 10 mV

Vstep 10 mV

Tpu 20 ms

Tpe 50 ms

N 1 N

Ne 0 N

Load Save Default

Click to enlarge

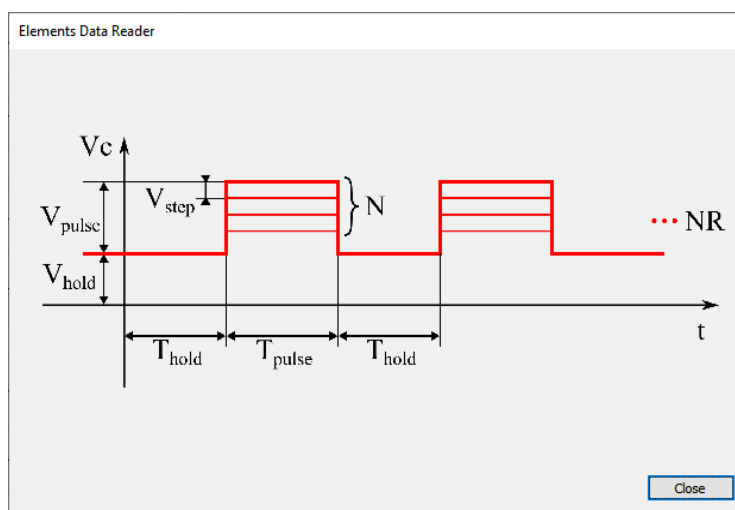

The software also performs a rules check for the correctness of the set parameters. A warning message is displayed if the parameters are invalid and a popup window opens if the user tries to apply such an invalid protocol.



Apply a voltage protocol

Once set the desired parameters, click on the Apply button to start applying the voltage protocol to the DUT.

To quickly apply a protocol when the experiment is running, keyboard shortcut Ctrl + 'Protocol Number' can be used. For instance Ctrl + '1' will apply the triangular wave and Ctrl + '2' seal test protocol and so on.

Lock/Unlock holding voltage

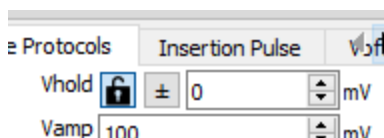

A small lock icon is available on the left of the Vhold control. When this button is pressed (lock open) the Vhold value can be set separately for different voltage protocols, so changing the selected voltage protocol will recall the Vhold value memorized for the newly selected protocol. This can be useful in cases in which each protocol has a different working voltage, and the Vhold must change accordingly when changing the selected protocol. When the button is released (lock closed) the Vhold value is locked for all voltage protocols, so changing the selected voltage protocol does not change the Vhold value. This can be useful in cases in which it is most important to keep the Vhold stable throughout the experiment, independently of the selected protocol.

Save and Load protocols

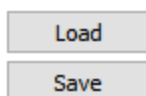

Commonly used protocols and their parameters can be saved for future usage by clicking on the Save button. This will create a .trial file with the parameters of the saved voltage protocol that can be easily loaded on following EDR sessions.

Alt + 'S' and Alt + 'L' shortcuts respectively Save the active protocol and Load the desired protocol.

To quickly apply your custom and standardly used protocol save it as .trial file, load it and click the "Apply" button (or the proper the keyboard shortcut).